

NOTES:

1. SwaleGard® body shall be fabricated from petroleum resistant fiberglass, per UL-MH19409.
2. Metal components shall be fabricated from either mild steel, (hot dipped galvanized per ASTM A123), or stainless steel Type 304.
3. Install SwaleGard® on permeable bedding, (drain rock or sand) and nonwoven geotextile filter cloth. Bedding shall be a minimum depth of 12 inches beneath the bottom of fiberglass body.
4. SwaleGard® pre-filter is supplied with sump outlet pipe connection stub. Outlet pipe assembly can be configured to accommodate sub-surface flow (as shown), or flow to swale surface. (See Grassy Swale drawing number SG-0001). Outlet pipe assembly supplied by others.
5. Contact manufacturer for use within high ground water areas, or in areas with low perk rates / impervious ground conditions.



Inlet Filtration

SwaleGard®

Parkway Culvert Prefilter



Oldcastle®
Stormwater Solutions

7921 Southpark Plaza, Suite 200 | Littleton, CO | 80120 | Ph: 800.579.8819 | oldcastlestormwater.com

THIS DOCUMENT IS THE PROPERTY OF OLDCASTLE PRECAST, INC. IT IS SUBMITTED FOR REFERENCE PURPOSES ONLY AND SHALL NOT BE USED IN ANY WAY INJURIOUS TO THE INTERESTS OF SAID COMPANY. COPYRIGHT © 2010 OLDCASTLE PRECAST, INC. ALL RIGHTS RESERVED.

DRAWING NO. SG-0002	REV F	ECO ECO-0139 JPR 2/8/16	DATE JPR 9/18/06	SHEET 1 OF 2
------------------------	----------	-------------------------------	---------------------	--------------

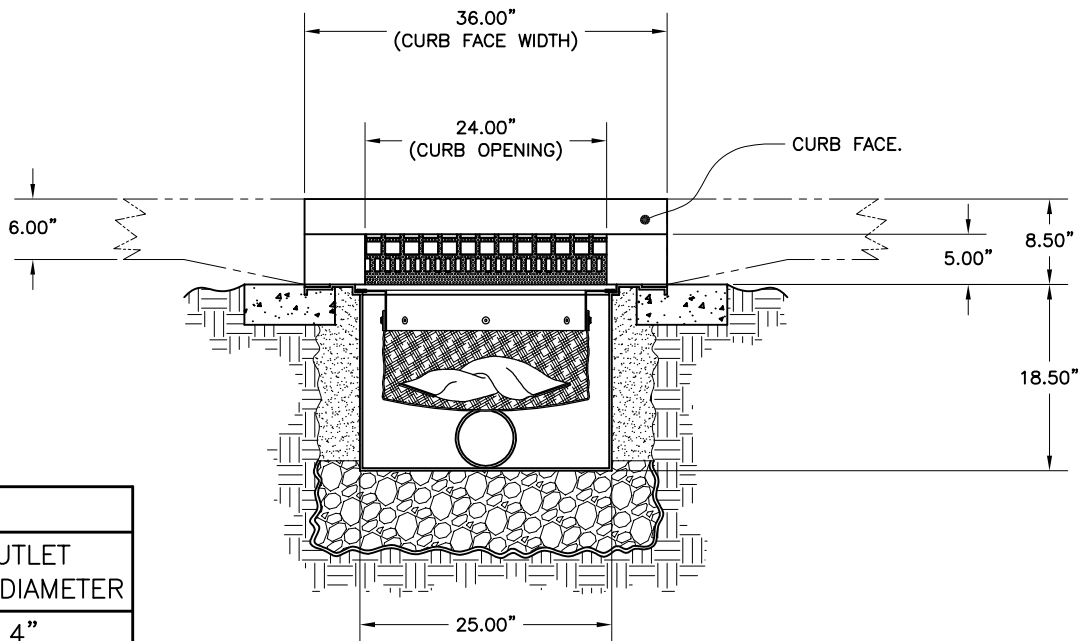
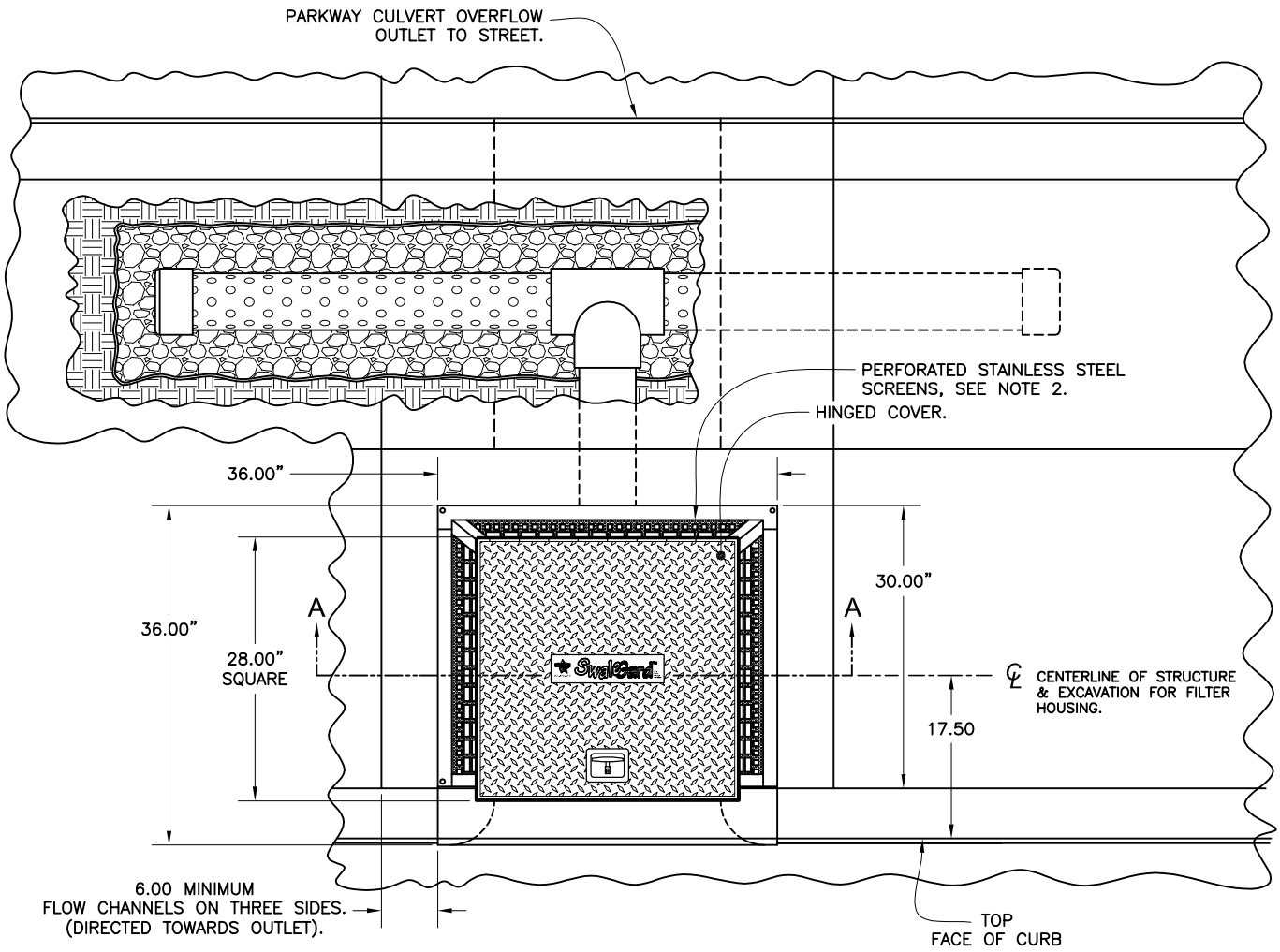

TABLE

MODEL NUMBER	OUTLET PIPE DIAMETER
FF-PC24-4	4"
FF-PC24-6	6"

SECTION A-A

(SECTION IS FROM BELOW
CURB OPENING & FRAME ONLY)

U.S. PATENT NUMBER 6,905,599



Inlet
Filtration

SwaleGard®

Parkway Culvert Prefilter



Oldcastle®
Stormwater Solutions

7921 Southpark Plaza, Suite 200 | Littleton, CO | 80120 | Ph: 800.579.8819 | oldcastlestormwater.com
THIS DOCUMENT IS THE PROPERTY OF OLDCASTLE PRECAST, INC. IT IS SUBMITTED FOR REFERENCE PURPOSES ONLY AND SHALL NOT BE USED IN ANY WAY INJURIOUS TO THE INTERESTS OF SAID COMPANY. COPYRIGHT © 2010 OLDCASTLE PRECAST, INC. ALL RIGHTS RESERVED.

DRAWING NO. SG-0002	REV F	ECO ECO-0139	DATE JPR 2/8/16	DATE JPR 9/18/06	SHEET 2 OF 2
------------------------	----------	-----------------	--------------------	---------------------	--------------